



型号(Type): **HB80 1.2V (扣式镍氢电池)**

单颗电池规格 Specifications of single cell

|                                     |                   |  |   |
|-------------------------------------|-------------------|--|---|
| 标称电压<br>Nominal voltage             |                   | 1.2V   |   |
| 容量<br>Capacity                      | 0.2C 放电 Discharge |  |   |
|                                     | 最小 Minimum        | 70mAh  |   |
|                                     | 典型 Typical        | 80mAh  |   |
| 尺寸<br>Dimensions                    | 直径 Diameter       | 参照以下产品尺寸图                                      |   |
|                                     | 高 Height          |  |   |
| 大约重量<br>Weight(Approximately)       |                   | 克 gram<br>3.2                                  |   |
| 内阻<br>Internal Impedance At 1000 Hz |                   | $\leq 500\text{m}\Omega$<br>(充电后 After Charge) |   |
| 充电<br>Charge                        | 标准 Standard       | 8mA(0.1C) $\times$ 16hrs                       |   |
|                                     | 快速 Rapid          | 16mA(0.2C) $\times$ 1.1hrs                     |   |
| 放电电流 Discharge current              |                   | $\leq 40\text{mA}$                             |   |
| IEC 循环寿命 IEC cycle life             |                   | $\geq 500$                                     |   |
| 环境温度<br>Ambient temperature         | 充电<br>Charge      | 标准 standard                                    | $0^{\circ}\text{C}$ to $40^{\circ}\text{C}$   |
|                                     |                   | 快速 Rapid                                       | $0^{\circ}\text{C}$ to $40^{\circ}\text{C}$   |
|                                     | 放电 Discharge      |  | $-10^{\circ}\text{C}$ to $45^{\circ}\text{C}$ |
|                                     | 贮藏 Storage        |  | $0^{\circ}\text{C}$ to $25^{\circ}\text{C}$   |

单颗电池尺寸包括 PVC (Dimensions with tube) (mm)

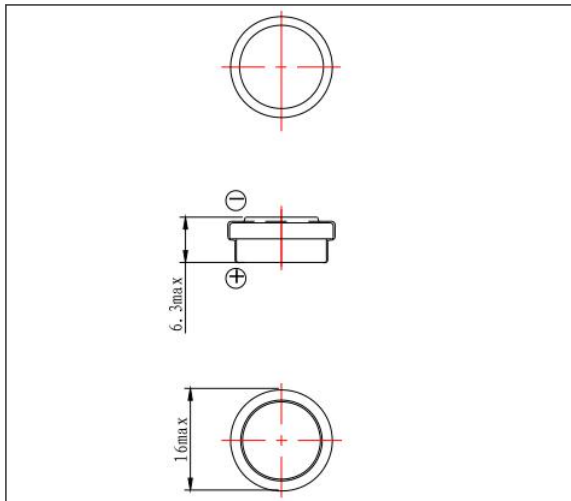

备注 Note:

- 标称容量是指  $20^{\circ}\text{C}$  时 0.2C 放电容量  
Nominal capacity, rated at 0.2C  $20^{\circ}\text{C}$ .
- 容量只作为参考  
Average capacity, for reference only.
- 重量和内阻也作为参考  
Weight and internal impedance are For reference.
- 寿命测试依照 IEC 标准  
Standard according as IEC of test cycle life.

典型特征 Typical characteristics

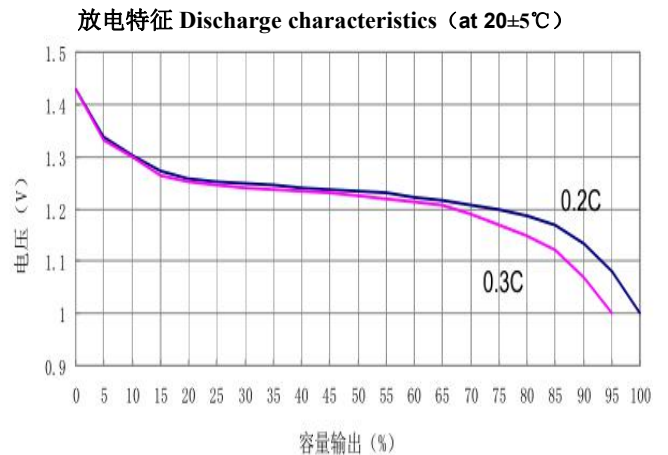
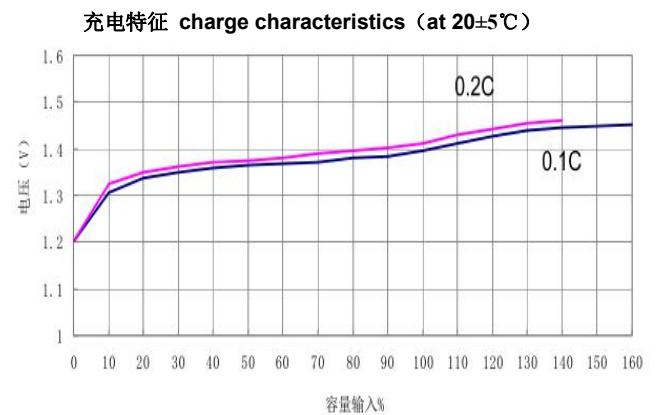
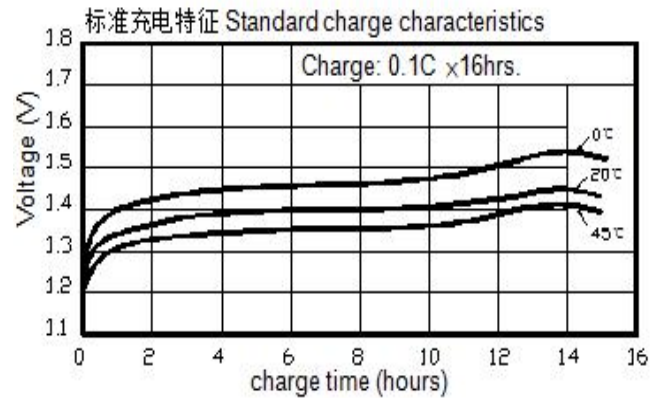

荷电保持 Charge retention (at  $20\pm 5^{\circ}\text{C}$ )

