

# Primary lithium batteries

## LO 30 SHX

3.0 V Primary lithium-sulfur dioxide (Li-SO<sub>2</sub>)  
 Very high drain and pulse capability  
 "Thin" D-size spiral cell



### Benefits

- High and stable discharge voltage
- Superior pulse capability
- Performance not affected by cell orientation
- Long storage possible before use
- Ability to withstand extreme temperature

### Key features

- Low self-discharge rate  
*(less than 3% after 1 year of storage at +20°C)*
- Hermetic glass-to-metal sealing
- Built-in safety vent  
*(at the negative end of the cell)*
- Restricted for transport *(class 9)*
- UL Component Recognition  
*(File Number MH 15076)*
- Meets shock, vibration and other environmental requirements of military specifications
- Made in the USA

### Main applications

- Radiocommunications and other military applications
- Beacons and Emergency Location Transmitters
- Sonobuoys

### Cell size reference

"Thin" D

### Electrical characteristics

*(typical values for cells stored for one year or less)*

Nominal capacity 5.75 Ah  
*(at 0.2 A +20°C 2.0 V cut off. The capacity restored by the cell varies according to current drain, temperature and cut off)*

Open circuit voltage (at +20°C) 3.0 V

Nominal voltage (at 0.6 A +21°C/+70°F) 2.8 V

Maximum recommended continuous current 3 A  
*(to avoid over-heating. Higher currents possible, consult Saft)*

Pulse capability : Typically up to 10 A  
*(The voltage readings may vary according to the pulse characteristics, the temperature, and the cell's previous history. Fitting the cell with a capacitor may be recommended in severe conditions. Consult Saft)*

Storage *(recommended possible without leakage)* +30°C (+86°F) max  
 -60°C/+85°C  
 (-76°F/+185°F)

Operating temperature range -60°C/+70°C  
 (-76°F/+158°F)

*(Short excursions up to +85°C possible at currents below 1 A)*

### Physical characteristics

Diameter *(max)* 29.0 mm (1.14 in)

Height *(max)* 62.5 mm (2.46 in)

Typical weight 63 g (2.21 oz)

Li metal content 1.9 g

Standard cell comes with resin potting in the topshell area and two radial 0.15 mm - thick nickel tabs

Different configurations available on request.



# LO 30 SHX

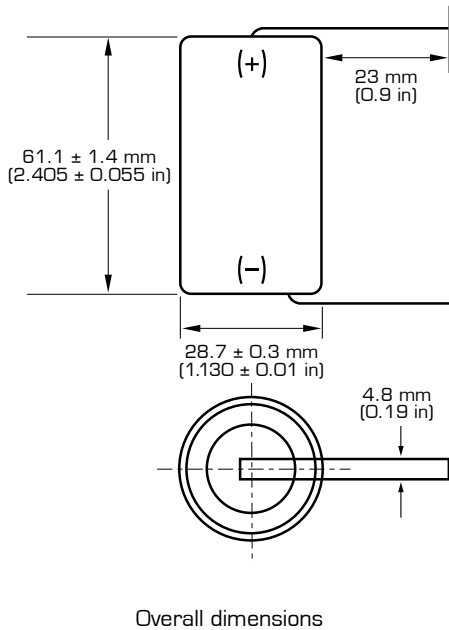

## Handling precautions

- Cell is pressurised.
- Do not puncture, open or mutilate.
- Do not obstruct the safety vent mechanism.
- Do not short circuit or charge.
- Do not expose to fire or temperatures above +70°C (+158°F).

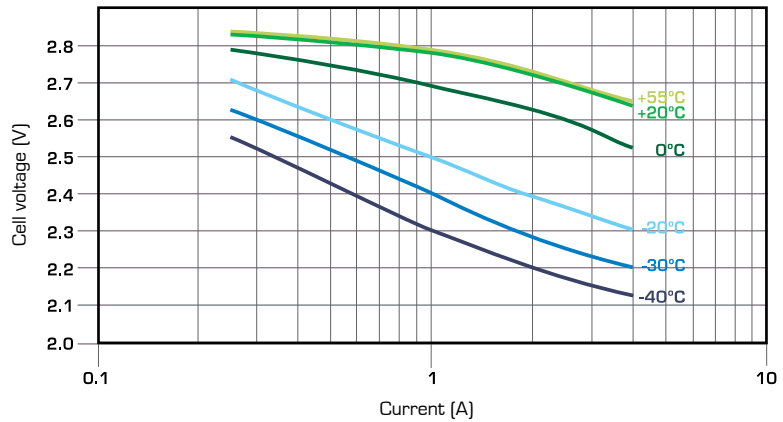

Voltage at mid-discharge versus Current and Temperature (2.0 V cut off)

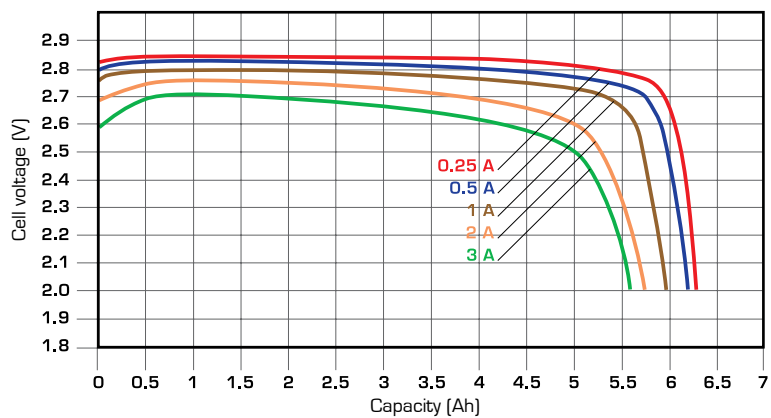

Typical discharge profiles at +20°C

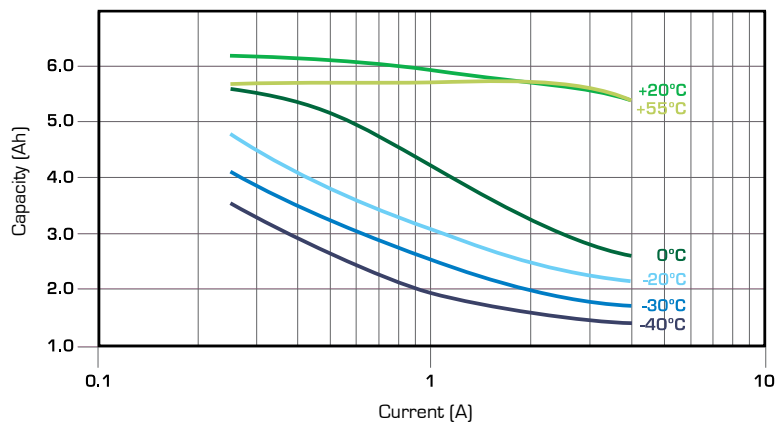

Capacity versus Current and Temperature (continuous discharges - 2.0 V cut off)

Doc. N° 31035-2-1116

Information in this document is subject to change without notice and becomes contractual only after written confirmation by Saft.

For more details on primary lithium technologies please refer to Primary Lithium Batteries Selector Guide Doc N° 31048-2.

Published by the Communications Department.

Photo credit: Saft.

Société anonyme au capital de 31 944 000 €  
RCS Bobigny B 383 703 873

Produced by Arthur Associates.

