

Primary lithium battery

LO 35 SX

3.0 V Primary lithium-sulfur dioxide (Li-SO₂)

High drain capability

²/₃ C-size spiral cell



Benefits

- High and stable discharge voltage
- High pulse capability
- Performance not affected by cell orientation
- Long storage possible before use
- Ability to withstand extreme temperature
- Non-restricted for transport

Key features

- Low self-discharge rate
(less than 3 % after 1 year of storage at + 20°C)
- Hermetic glass-to-metal sealing
- Built-in safety vent
(at the negative end of the cell)
- UL Component Recognition
(File Number MH 15076)
- Meets shock, vibration and other environmental requirements of military specifications
- Made in the USA

Main applications

- Radiocommunications and other military applications
- Automotive telematics

Cell size reference

²/₃ C

Electrical characteristics

(typical values for cells stored for one year or less)

Nominal capacity 2.20 Ah

(under 650 mA + 20°C 2.0 V cut-off. The capacity restored by the cell varies according to current drain, temperature and cut-off)

Open circuit voltage (at + 20°C) 3.0 V

Nominal voltage (at 250 mA + 20°C) 2.8 V

Maximum recommended continuous current 2.0 A
(to avoid over-heating. Higher currents possible, consult Saft)

Pulse capability : Typically up to 5 A

(The voltage readings may vary according to the pulse characteristics, the temperature, and the cell's previous history. Fitting the cell with a capacitor may be recommended in severe conditions. Consult Saft)

Storage (recommended) + 30°C (+ 86°F) max.
(possible without leakage) - 60°C/+ 85°C
[- 76°F/+ 185°F]

Operating temperature range - 60°C/+ 70°C
[- 76°F/+ 158°F]

(Short excursions up to + 85°C possible at currents below 1 A)

Physical characteristics

Diameter (max) 25.9 mm (1.020 in)

Height (max; finish without radial tabs) 35.9 mm (1.413 in)

Typical weight 30 g (1.06 oz)

Li metal content 0.8 g

Standard cell comes with resin potting in the topshell area and two radial 0.15 mm - thick nickel tabs

Other configurations available on request.



LO 35 SX

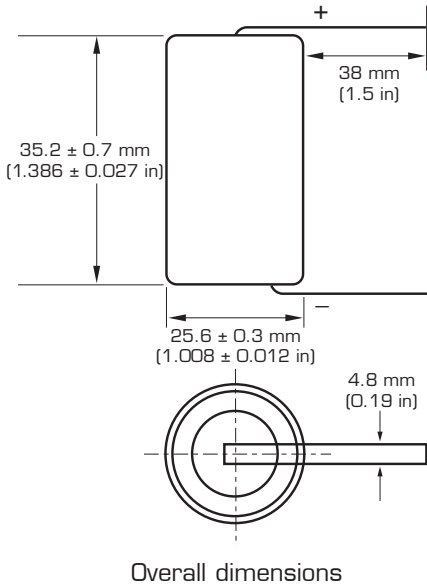

Handling precautions

- Cell is pressurised at ambient temperature.
- Do not puncture, open or mutilate.
- Do not obstruct the safety vent mechanism.
- Do not short circuit or charge.
- Do not expose to fire or temperatures above +70°C (+158°F).

Voltage plateau versus Current and Temperature

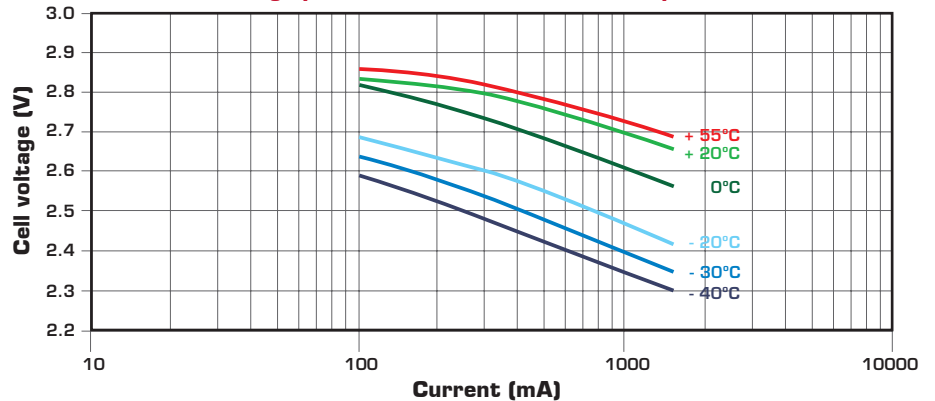

Typical discharge profiles at +20°C

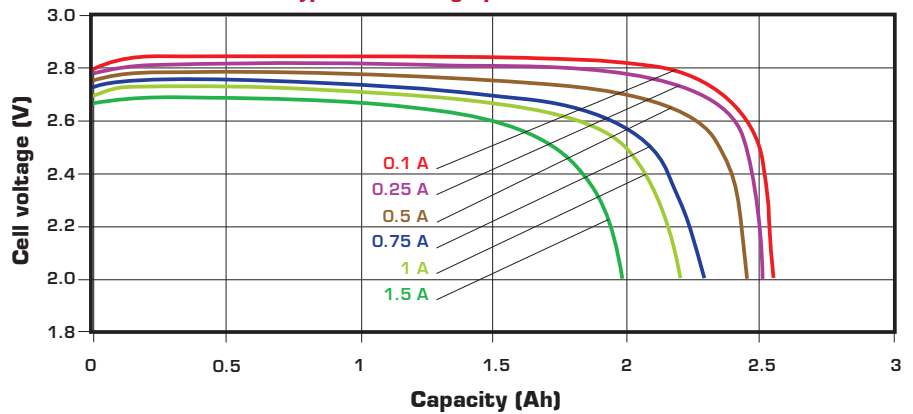

Restored Capacity versus Current and Temperature (2.0 V cut-off)

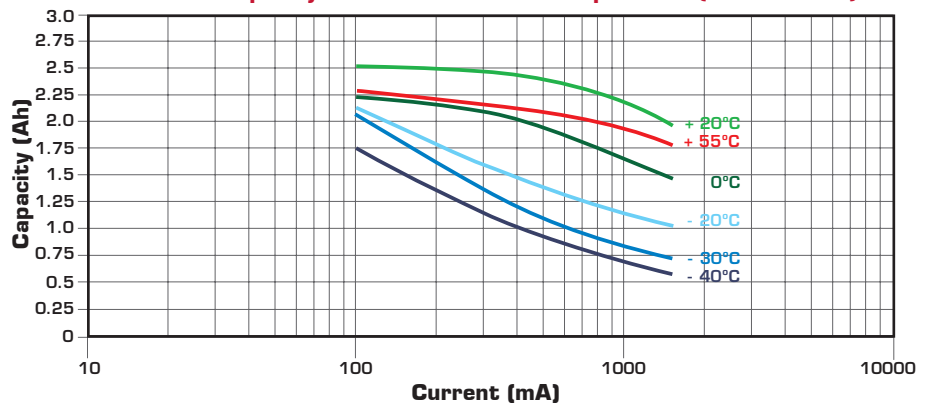

Doc. N° 31083-2-0908

Information in this document is subject to change without notice and becomes contractual only after written confirmation by Saft.

For more details on primary lithium technologies please refer to Primary Lithium Batteries Selector Guide Doc N° 31048-2.

Published by the Communications Department.

Photo credit: Saft.

Société anonyme au capital de 31 944 000€

RCS Bobigny B 383 703 873

Produced by Arthur Associates Limited.



SAFT